

Engineering Specification

Job Name _____

Contractor _____

Job Location _____

Approval _____

Engineer _____

Contractor's P.O. No. _____

Approval _____

Representative _____

Series 909RPDA

Reduced Pressure Detector Assembly

2½" – 10"

Series 909RPDA Reduced Pressure assembly is used in health hazard application and designed exclusively for use in accordance with water utility authority containment requirements. It is mandatory to prevent the reverse flow of fire protection system substances, such as glycerin wetting agents, stagnant water, and water of non-potable quality from being pumped or siphoned into the potable water line.

The modular check design concept facilitates maintenance and assembly access. The iron components of the backflow preventer are coated with ArmorTek®, a patented three-part advanced epoxy system engineered to reduce microbial-induced corrosion (MIC) and protect exposed metal substrate. All sizes are standardly equipped with AWWA epoxy coated, UL Classified and FM Approved OSY resilient seated gate valves, CFM (cubic feet per minute) or GPM (gallon per minute) meter and ball type test cocks. A pressure differential relief valve is located in a zone between the check valves.

The series includes a flood sensor to detect excessive water discharges from the relief valve. The sensor is installed on the assembly exterior and does not alter assembly functions or certifications. The sensor relays a signal that triggers notification to facility personnel for corrective action, thus limiting flooding and costly damage.

NOTICE

An add-on connection kit (sold separately) is required to activate the flood sensor. Without the connection kit, the sensor is a passive component that has no communication with any other device. (For more information download RP/IS-909/909RPDA.)

NOTICE

Use of the flood sensor does not replace the need to comply with all required instructions, codes, and regulations related to installation, operation, and maintenance of this product, including the need to provide proper drainage in the event of a discharge.

Watts is not responsible for the failure of alerts due to connectivity issues, power outages, or improper installation.

NOTICE

The information contained herein is not intended to replace the full product installation and safety information available or the experience of a trained product installer. You are required to thoroughly read all installation instructions and product safety information before beginning the installation of this product.

Inquire with governing authorities for local installation requirements.

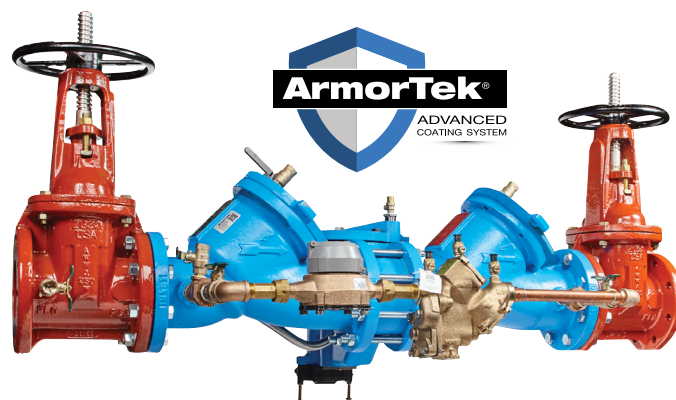

909RPDA with flood sensor

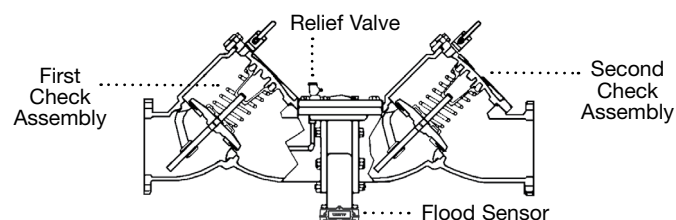

Features

- Body construction fused epoxy coated cast iron
- Replaceable stainless steel seats
- Maximum flow at low pressure drop
- Compact for economy combined with performance
- Design simplicity for easy maintenance
- ArmorTek coating technology to resist corrosion of internals
- Furnished with 5/8" x 3/4" (16 x 19 mm) meter
- Air-in/Water-out relief valve design provides maximum capacity during emergency conditions.
- No special tools required
- Sensor on relief valve for flood detection
- Flood alerts feature activated with add-on sensor connection kit, compatible with BMS and cellular network communication

Watts product specifications in U.S. customary units and metric are approximate and are provided for reference only. For precise measurements, please contact Watts Technical Service. Watts reserves the right to change or modify product design, construction, specifications, or materials without prior notice and without incurring any obligation to make such changes and modifications on Watts products previously or subsequently sold.

Specification

A Reduced Pressure Detector assembly shall be installed on fire protection systems when connected to a public water supply. Degree of hazard present is determined by the local authority having jurisdiction. The unit shall be a complete assembly including UL Classified and FM Approved OSY shutoff valves. Including an auxiliary line consisting of an approved backflow preventer and water meter. Iron components of the backflow preventer shall incorporate ArmorTek coating technology, delivering integrated protection against electrochemical corrosion and microbial-induced corrosion. The assembly shall meet the requirements of AWWA C511-92; ASSE 1047; UL Classified File No. EX3185; CSA B64 and USC Manual 8th. Edition. Assembly shall be Watts Series 909RPDA and shall include a sensor on the relief valve for flood detection.

Model/Option

- FS – Sensor on the relief valve for flood detection
- OSY – UL Classified and FM Approved outside stem and yoke resilient seated gate valves
- CFM – Cubic feet per minute meter
- GPM – Gallons per minute meter
- LF – Less shutoff valves

Materials

- Body: Cast iron
- Coating: ArmorTek powder coating, applied to internal and external surfaces
- Seat and Disc Holder: Stainless steel
- Discs: Rubber
- Trim: Stainless steel
- Test Cocks: Bronze

Pressure — Temperature

- Temperature Range: 33°F – 140°F (0.5°C – 60°C) continuous
- Maximum Working Pressure: 175 psi (12.1 bar)

Series 909AG Air Gaps

When installing a drain line, use Series 909 air gaps on Model 909 backflow preventers.

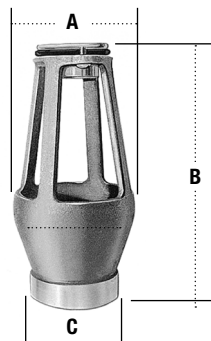

How It Operates

The unique relief valve construction incorporates two channels: one for air, the other for water. When the relief valve opens, as in the accompanying air-in/water-out diagram, the right-hand channel admits air to the top of the reduced pressure zone, relieving the zone vacuum. The channel on the left then drains the zone to atmosphere. Therefore, if both check valves foul, and simultaneous negative supply and positive backpressure develops, the relief valve uses the air-in/water-out principle to stop potential backflow.

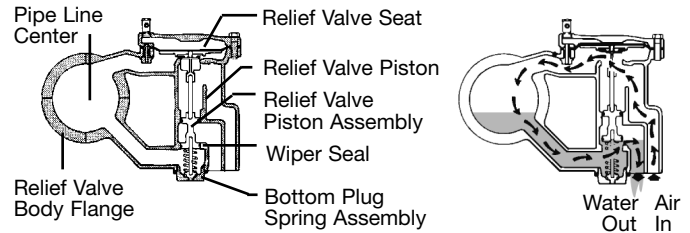

Standards

- AWWA C511-92; CSA B64
- USC Manual for Cross-connection Control, 8th Edition

Approvals



Approved by the foundation for Cross-Connection Control and Hydraulic Research at the University of Southern California

Dimensions — Weights

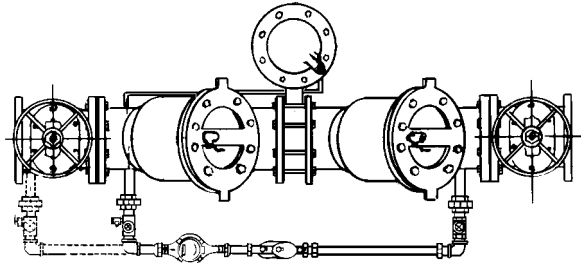

NOTE: Piping for 3" 909 will start from #1 gate valve and connect at #2 check valve.

Iron Body Model	Ordering Code	Series/Sizes	Dimensions			Weight	
			A in. mm	B in. mm	C in. mm	lb	kg
909AG-F	0881378	1¼" – 3" 009/909					
		1¼" – 2" 009 M1	4¾" 111	6¾" 171	2 51	3.25	1.47
		2" 009 M2					
909AG-K	0881385	4" – 6" 909 8" – 10" 909 M1	6¾" 162	9¾" 244	3 76	6.25	2.83
909AG-M	0881387	8" – 10" 909	7¾" 187	11¼" 286	4 102	15.50	7.03

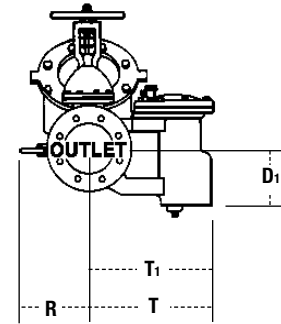
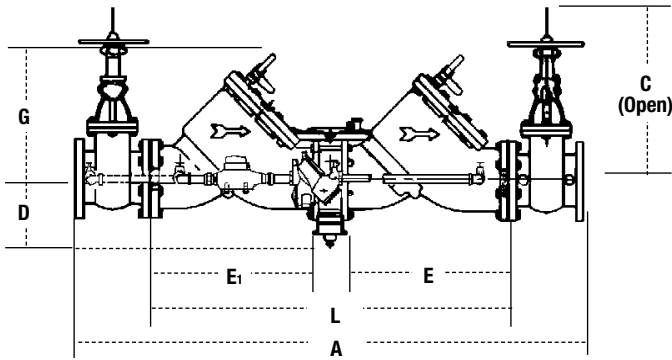

SIZE	DIMENSIONS																WEIGHT					
	A		C		D		D1		E, E1		G		L		R		T		T1		lb	kg
in.	in.	mm	in.	mm	in.	mm	in.	mm	in.	mm	in.	mm	in.	mm	in.	mm	in.	mm	in.	mm		
2½	41¼	1070	16¾	416	5¼	133	4¼	114	12	305	7	178	26½	664	14	356	9	229	7¾	194	230	104
3	42¼	1070	18¾	479	5¼	133	4¼	114	12	305	7	178	26½	664	14	356	9	229	7¾	194	230	104
4	55½	1400	22¾	578	6	152	5½	149	17	432	9½	241	37	940	15	381	13¾	346	11¾	299	470	213
6	65½	1664	30¾	765	6	152	6	152	20¾	527	14½	368	45	1130	16	406	13¾	346	11¾	299	798	362
8	78½	1994	37¾	959	9¾	248	8¾	219	26	660	18½	470	55¼	1403	17	432	18½	470	16¾	416	1456	660
10	93¾	2378	45¾	1162	9¾	248	8¾	219	32	813	21½	546	67½	1715	18	457	18½	470	16¾	416	2230	1012

Capacity

*Typical maximum flow rate (7.5 ft/s)

**UL rated flow

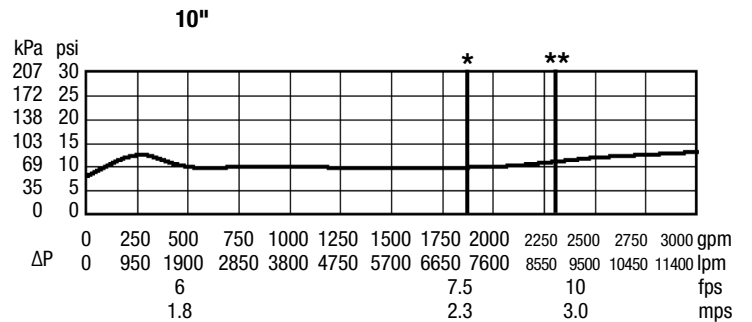
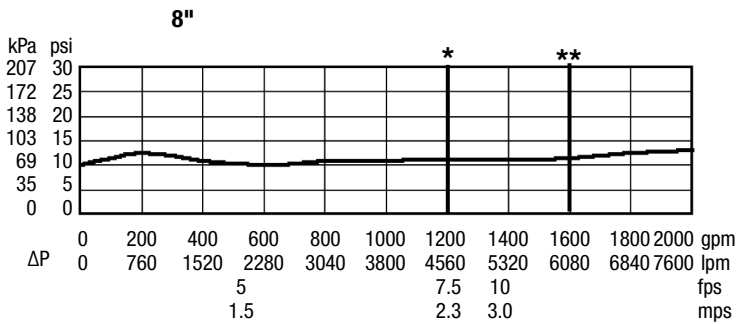
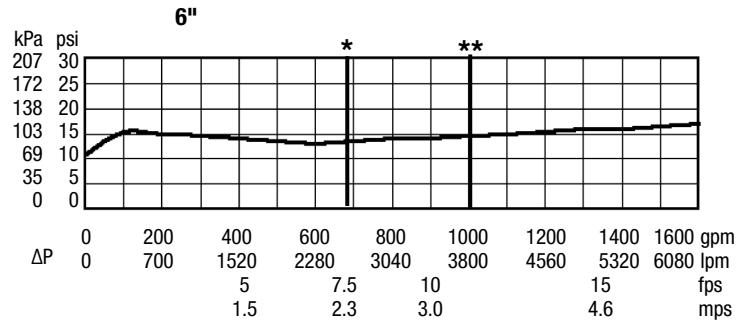
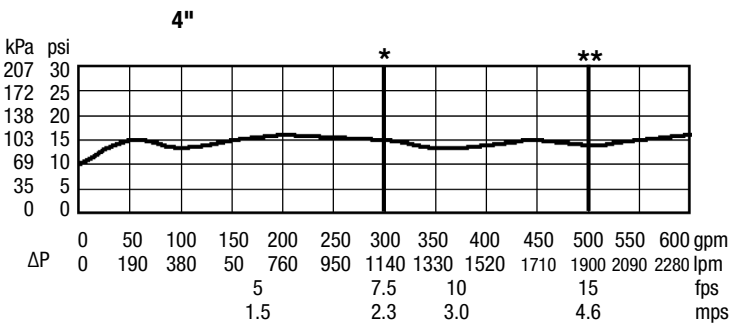
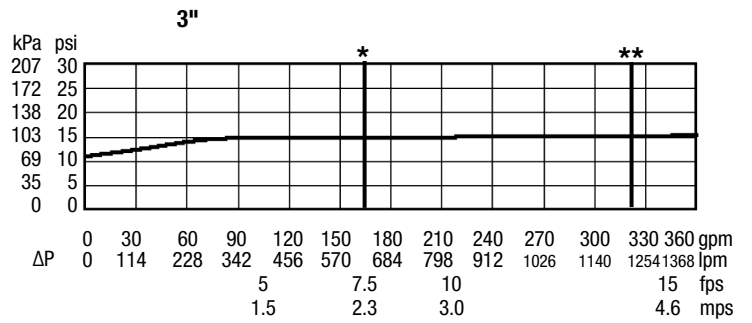
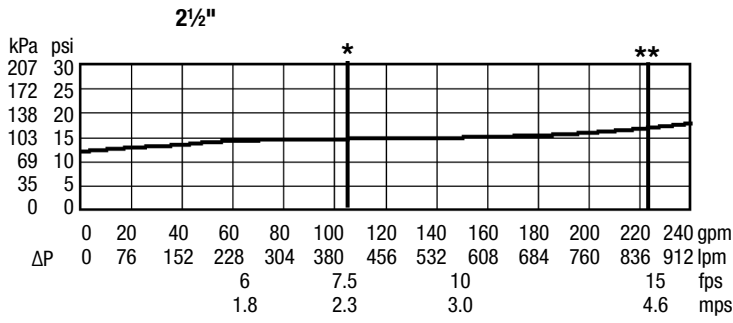

USA: T: (978) 689-6066 • Watts.com
 Canada: T: (888) 208-8927 • Watts.ca
 Latin America: T: (52) 55-4122-0138 • Watts.com